

virtuafit

FDR 2.0i Ergometer Crosstrainer

User manual

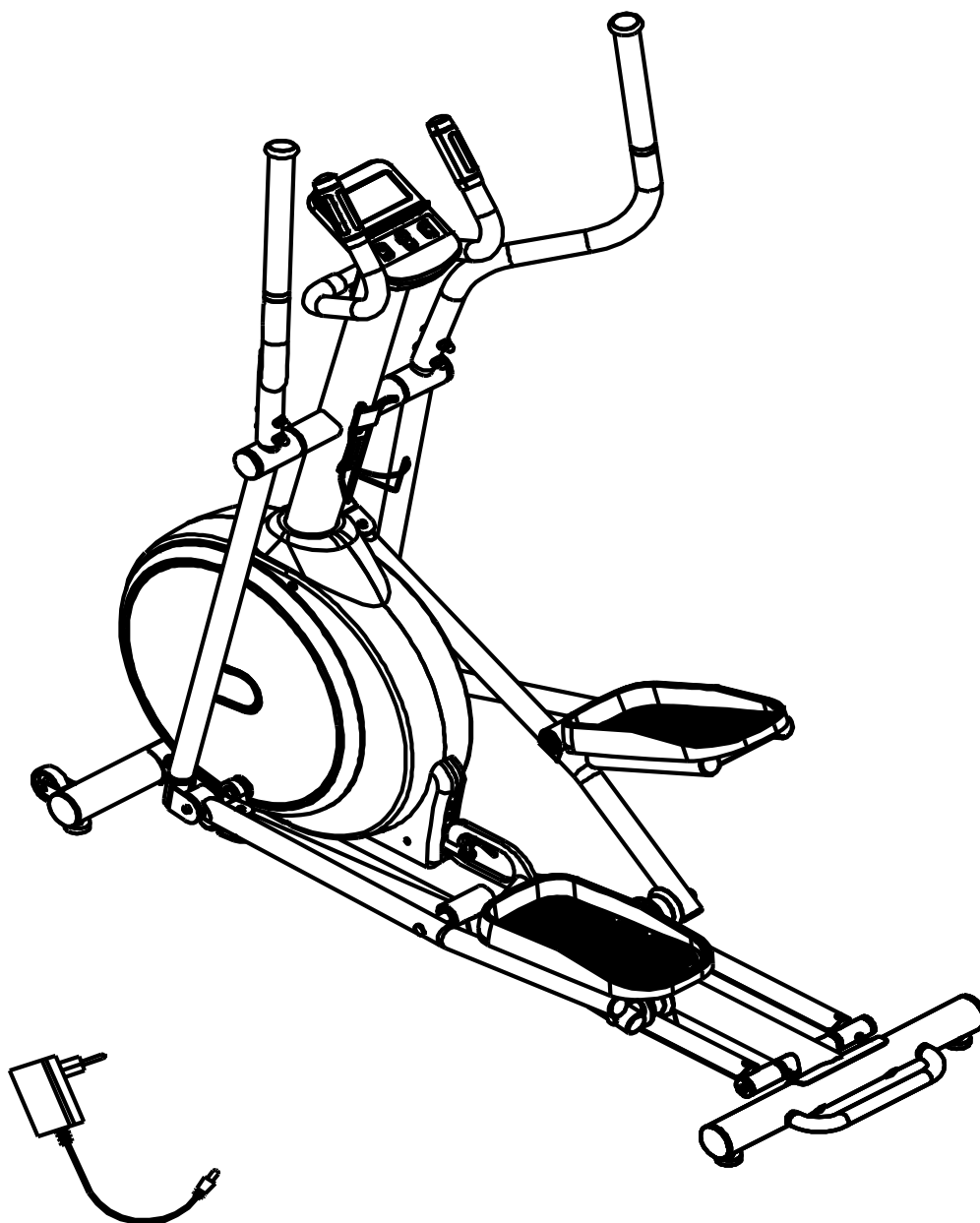

SAFETY INSTRUCTIONS	3 - 4
CHECKLIST	5
ASSEMBLY INSTRUCTIONS	6 - 9
ADJUSTMENTS GUIDE	10
MOVING THE DEVICE	10
MAINTENANCE	11
TROUBLE SHOOTING	12 - 13
CONTROL PANEL	14 - 21
APP INSTRUCTIONS	22
EXPLODED DRAWING	23 - 24
PARTS LIST	25 - 26
TRAINING INSTRUCTIONS	27

WARNING:

Before beginning any exercise program consult your physician. This is especially important for people who are over 35 years old or who have pre-existing health problems. Read all instructions before using any fitness equipment. Do not operate this device without properly fitted guards, as the moving parts can present a risk of serious injury if exposed.

ATTENTION

- It is important to read this entire manual before assembling and using the device. Safe and effective use can only be achieved if the device is assembled, maintained and used properly. It is your responsibility to ensure that all users of the device are informed of all warnings and precautions.
- Before starting any exercise program, you should consult your doctor to determine if you have any medical or physical conditions that could put your health and safety at risk, or prevent you from using the device properly. Your doctor's advice is essential if you are taking medication that affects your heart rate, blood pressure or cholesterol level.
- Be aware of your body's signals. Incorrect or excessive exercise can damage your health. Stop exercising if you experience any of the following symptoms: pain, tightness in your chest, irregular heartbeat, extreme shortness of breath, lightheadedness, dizziness or feelings of nausea. If you do experience any of these conditions you should consult your doctor before continuing with your exercise program.
- Keep children and pets away from the device. The device is designed for adult use only.
- Use the device on a solid, flat level surface with a protective cover for your floor or carpet. To ensure safety, the device should have at least 0.5 metres of free space all around it.
- Before using the device, check that the nuts and bolts are securely tightened.
- The safety of the device can only be maintained if it is regularly examined for damage and/or wear and tear.

- Always use the device as indicated. If you find any defective components while assembling or checking the device, or if you hear any unusual noises coming from the device during use, stop immediately. Do not use the device until the problem has been rectified.
- Wear suitable clothing while using the device. Avoid wearing loose clothing that may get caught in the device or that may restrict or prevent movement.
- The max user weight is 140 KGS. Braking ability is independent of speed.
- The device is not suitable for therapeutic use.
- Care must be taken when lifting or moving the device so as not to injure your back. Always use proper lifting techniques and/or seek assistance if necessary.
- Please keep the space at least 1 to 2 meter at the end of base frame to escape any accidents!
- Place the device on a clean and flat surface. Do not place the device on a thick carpet.
- The device is for indoor use and not for outdoor use to prevent damage. Keep the storage location dry, clean and flat. It is forbidden to use the device for purposes other than training.
- Only use the machine in an environment with an ambient temperature between 10 °C and 35 °C. Only store the device at an ambient temperature between 5 °C and 45 °C.

Warranty claim is excluded if the cause of the defect is the result of:

- Maintenance assembly and repair work not carried out by an official dealer.
- In the event of improper use, neglect and / or poor maintenance.
- Failure to maintain the device in accordance with the manufacturer's instructions (see the enclosed manual).

TOOLKIT

When you open the carton, and you will find the below parts in the carton:

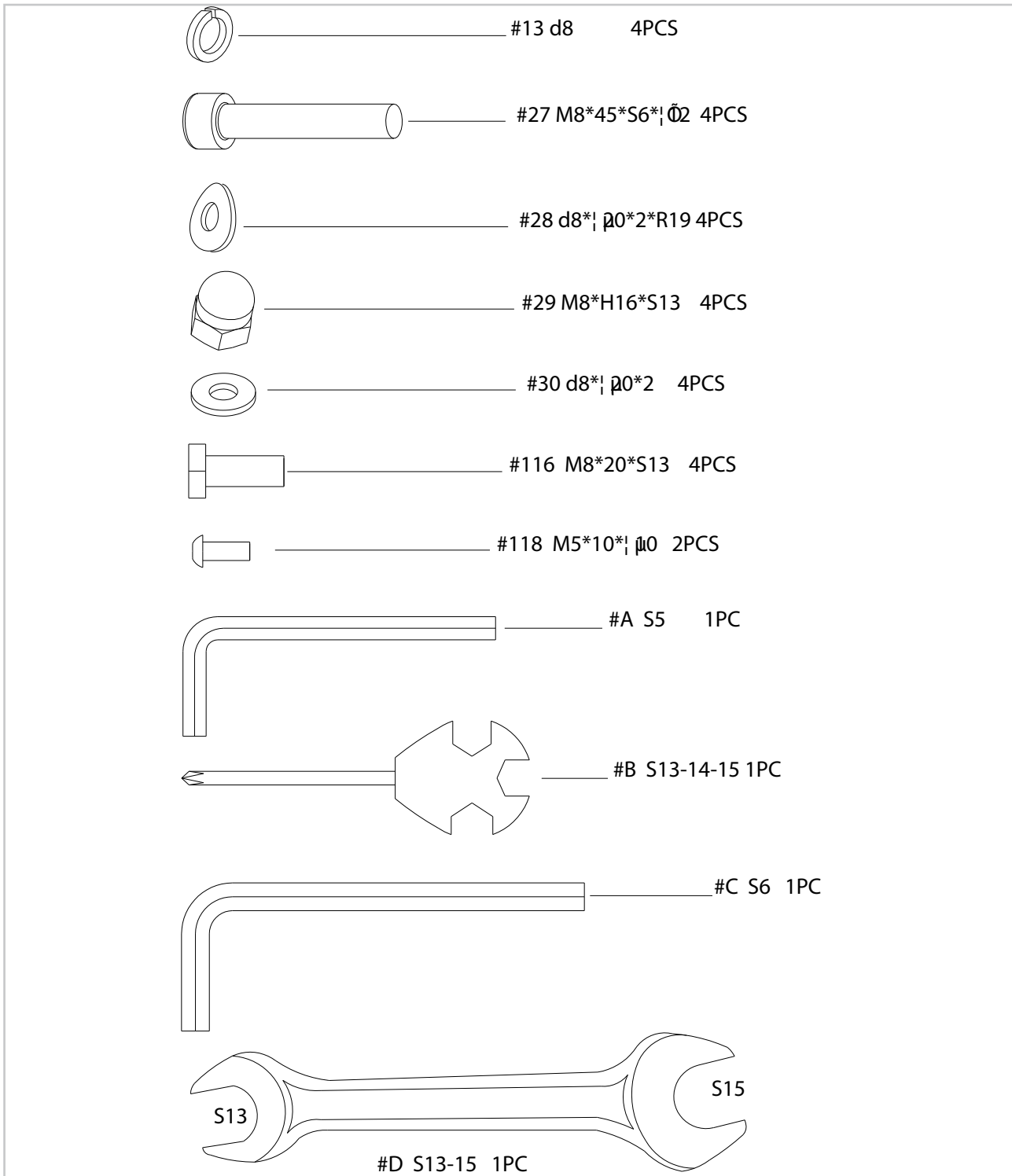

NOTE! Do not connect the appliance to the power before it has been completely assembled.

Missing parts: If you think you are missing certain parts in your package, carefully check the styrofoam and the device. Some parts (bolts, screws, etc.) are already attached to/in the device.

Error message: Ensure that all cables are carefully attached. The aluminum legs are very sensitive and must remain straight. Do you receive an error message after mounting your device? Then you have to straighten these aluminum legs again, this may cause the error message to disappear.

Socket screws: The device contains socket screws, make sure that the allen key is firmly in the bolt before you apply force to the key. In this way you prevent the head of the socket head screw from being rotated.

NOTE! *The transport wheels must be mounted on the front of the appliance.*

STEP 1

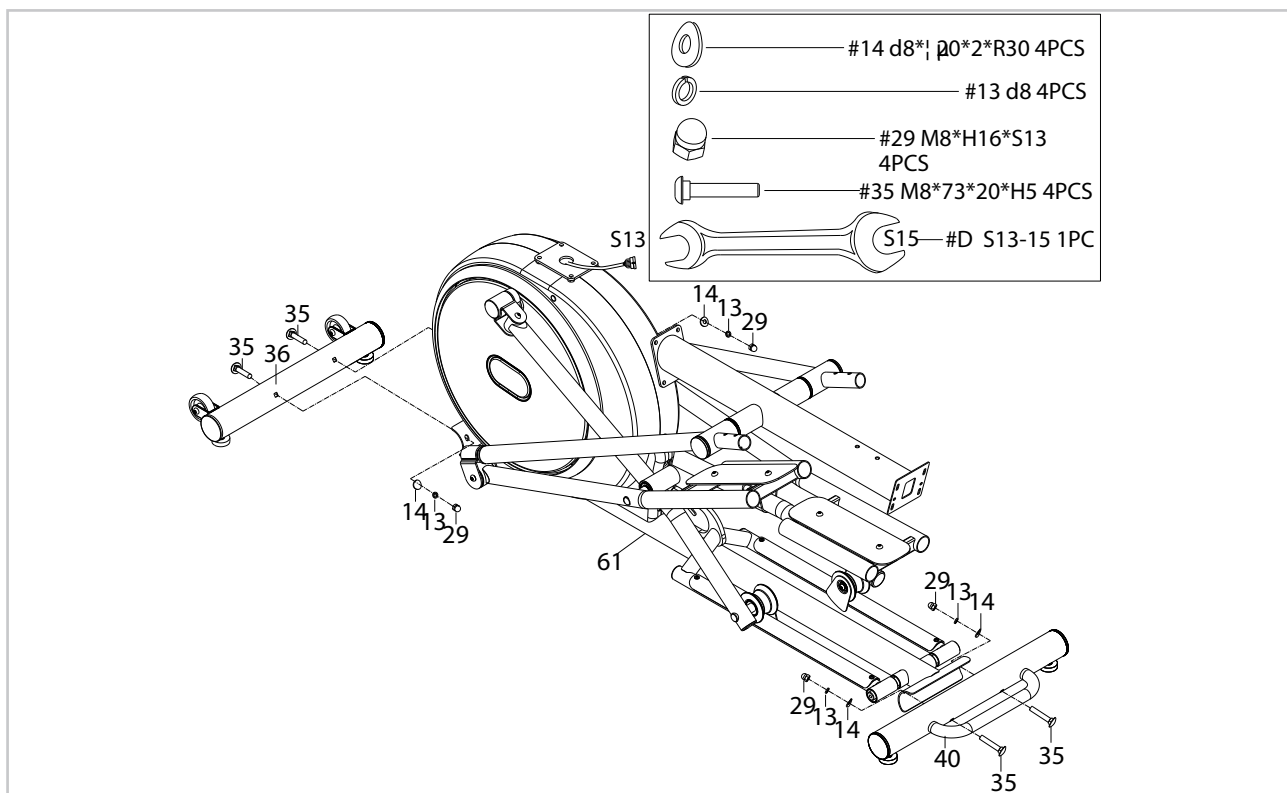

- Remove the square neck bolt (35), spring washer (13), arc washer (14) and cap nut (29) from the mainframe (61) first and then take off the paper tube.
- Fix the front and rear stabilizer (36)&(40) to the mainframe (61) with square neck bolt (35), spring washer (13), arc washer (14) and cap nut (29) by cross solid wrench (D).

STEP 2

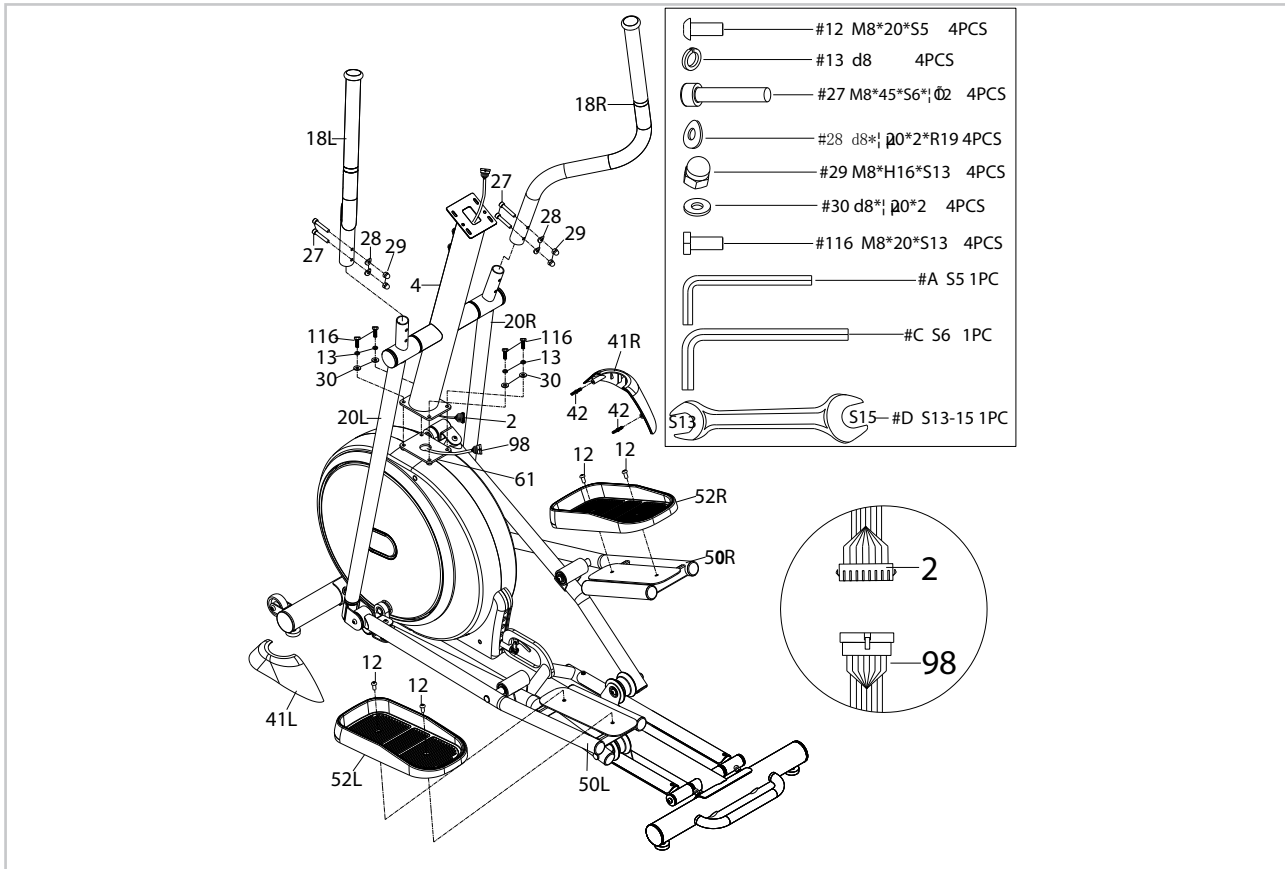

- Connect extension wire 1 (2) with extension wire 2 (98) first.
- Fix the handlebar post (4) to the mainframe (61), and then fix it with hexagonal bolt (116), spring washer (13), washer (30) by solid wrench (D).
- Fix the handlebar (18L/R) to the reciprocating bar (20L/R) separately with inner hex cylinder head bolt (27), arc washer (28), and cap nut (29) by solid wrench (D) and Allen wrench.
- Remove the inner hex pan head bolt (12) from the pedal support tube (50L/R) first, and then fix the pedal (52L/R) to the pedal support tube (50L/R).
- Connect the handlebar post cover (41L/R) by plastic connection bar (42).

STEP 3

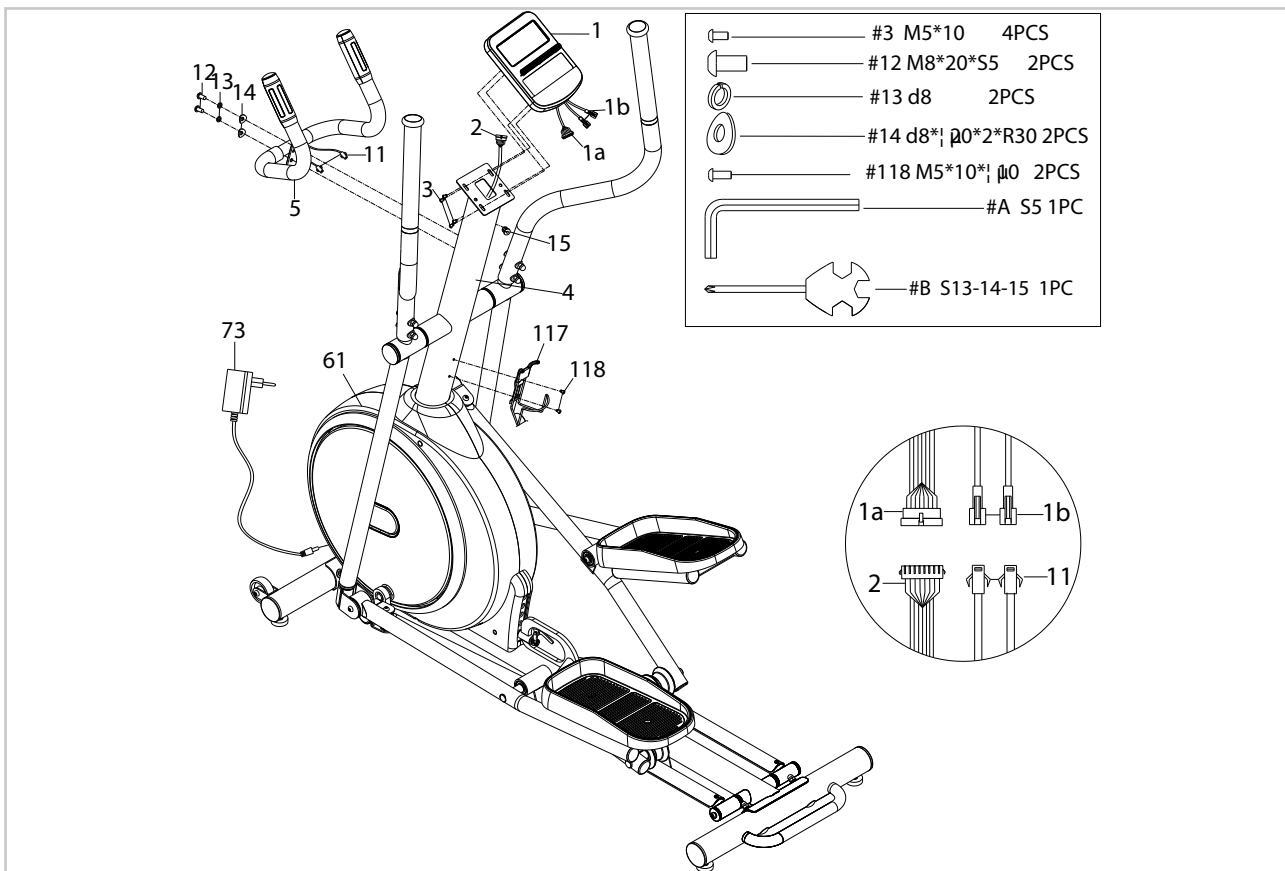

- Remove the inner hex pan head bolt (12), spring washer (13) and arc washer (14) from the handlebar post (4).
- Fix the middle handlebar (5) to the handlebar post (4) with inner hex pan head bolt (12), spring washer (13) and arc washer (14).
- Remove the cross pan head screw (3) from the display (1).
- Draw the handle pulse wire (11) from the handlebar post (4), and connect it with display wire (1b), meanwhile connect the extension wire 1(2) with display wire (1a).
- Press the wire holder into the hole.
- Fix the display (1) to the handlebar post (4) with cross pan head screw (3).
- Fasten the bottle holder (117) to the handlebar post (4) with cross pan head screw (118).

ADAPTER

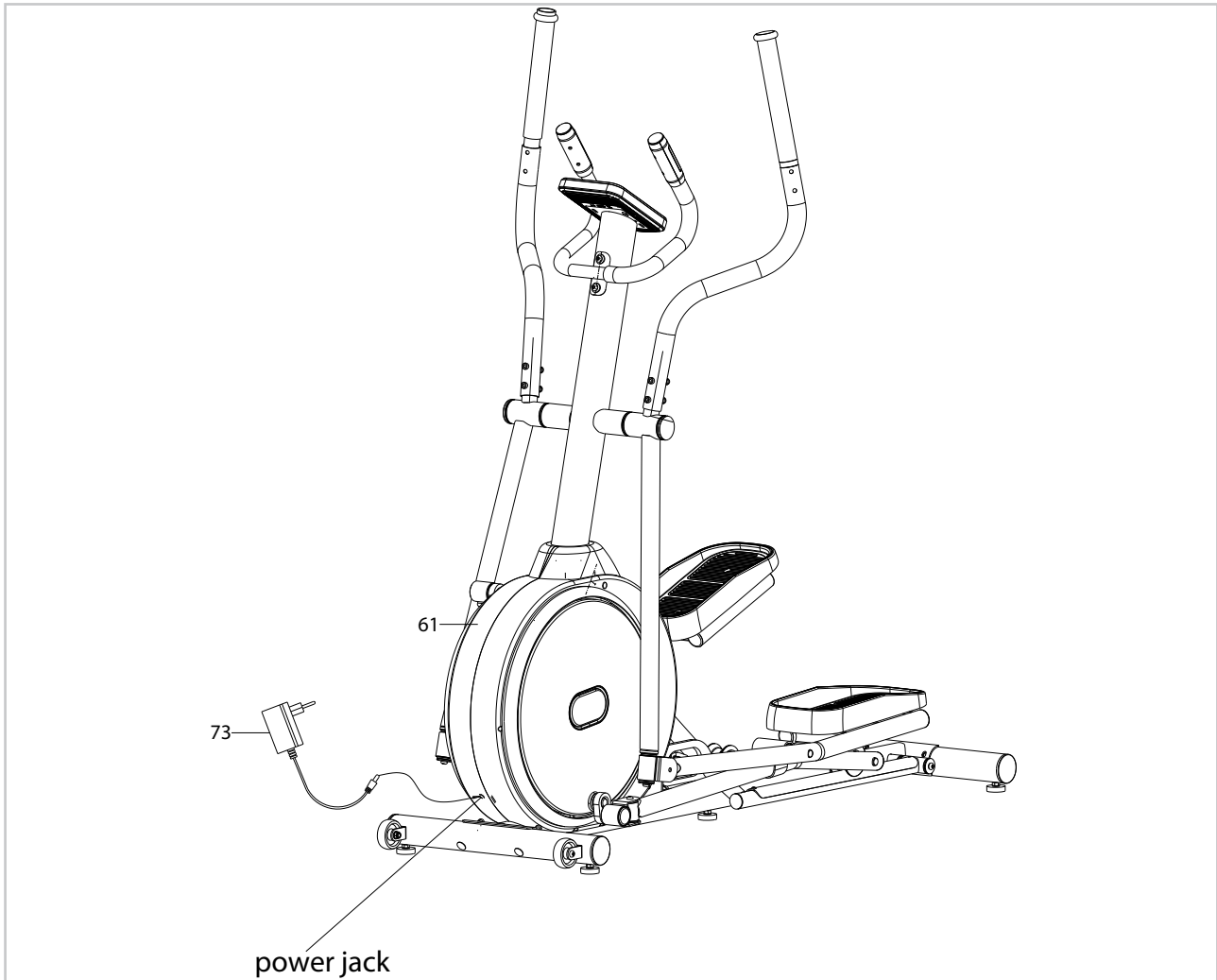

- The adapter connection is located on the front of the device (see image). Attach the adapter to the adapter connector and connect to AC power. You can now use the crosstrainer.
- Do not use until the machine has been fully assembled and inspected for correct performance in accordance with the User Manual.
- Inspect your machine to ensure that all hardware is tight and components are properly assembled.

LEVELING THE DEVICE

The machine needs to be leveled if your workout area is uneven or if the Rail Assembly is slightly off the floor. To adjust: Place the machine in your workout area. Safely stand on the back of the Rail Assembly for approximately 20 seconds. Step off the machine. Loosen the locking nuts and adjust the levelers until they all contact the floor. Adjust until the machine is level. Tighten the locking nuts.

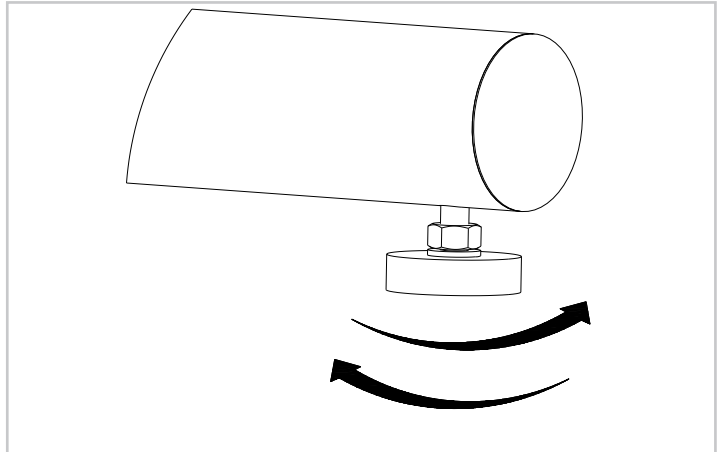

CHANGING INCLINE LEVELS

Hold the incline adjustment handle steadily, and then pull it out to the suitable position.

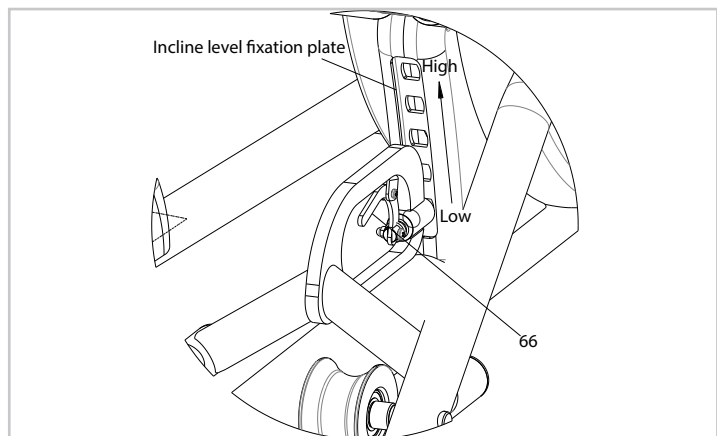

MOVING THE DEVICE

- Remove the power cord.
- Use the Transport Handle to carefully lift the machine onto the transport rollers.
- Push the machine into position.
- Carefully lower the machine into position.

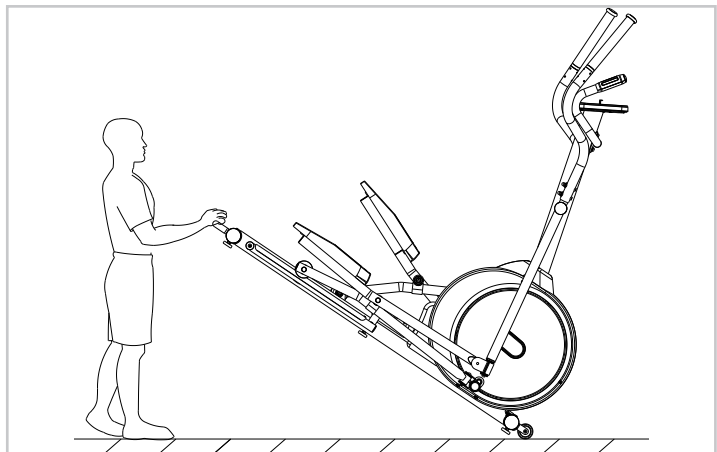

Safe and effective use can only be achieved if the device will be assembled and maintained well. It is your responsibility to ensure that the equipment is regularly maintained. Parts that are already used and / or damaged must be replaced before continuing using. The rower machine may only be used indoors and stored away, prolonged exposure to weathering and changes in temperature / humidity can have a serious impact on the electrical components and moving parts of the device.

DAILY MAINTENANCE

- Clean and remove sweat after each use Do not use aggressive cleaning agents and ensure that the device remains free of moisture.
- Check that the rail and the wheels under the seat are free from dust and dirt.

SEMI-ANNUAL MAINTENANCE

- Inspect all bolts and nuts in connection with moving parts of the device, tighten as required.
- Check the mobility of moving parts and components of the use equipment, silicone spray if necessary.

EXTEND SERVICE LIFE

- The upright is secured with Allen screws, make sure that the bolts are tight at all times. If the bolts are not tight enough anymore, this can cause cracking..
- If the crosstrainer has rails with wheels that roll over it, these rails/wheels every month to be greased with grease. This can be done with Vaseline (without acids) or with silicone oil.
- If a main switch is attached to the appliance (on / off), it should always be used after use be turned off.

Display shows no values

If the display does not show any values, you can try to check the sensor cables and the cables in the back of the display. If this still does not work, you can move the sensor slightly.

The device beeps

If necessary, lubricate parts with silicone spray. Check that all nuts and bolts are tightened. It may be that a screw is too loose or too tight, this creates friction and makes the device appear to beep. If this is the case, try to find out exactly where the beep comes from and then tighten or loosen this screw. It must always be possible to loosen the screws with your hands. If this is not possible, the screw is too tight.

No resistance

First check whether you can hear the motor running. You will hear the motor running briefly when you increase or decrease the resistance. If you hear the engine running, all electronics are in order, but the V-belt is probably over. You can then open the housing and put the V-belt back on it. If you do not hear the motor running, it is possible that the motor or the display is defective. First check whether the cable running upwards in the pipe is still properly connected.

Ticking sound

It is possible that the flywheel (in the housing) comes against a cable with each pedaling movement. This may be disturbing but will not permanently damage your crosstrainer. To fix this, open the housing and move the cable or fix it with for example a tie wrap.

Heart rate display is not functioning

There can be various reasons for this:

- The sensor cables that run from the heart rate sensor to the display are not properly installed or have become detached during use.
- The sensors may become damp, dirty or greasy. So you have to clean them regularly.

The console is not working

If there is no signal when pedaling, check if the cable is properly attached.

ERROR CODES

CODE	PROBLEM	SOLUTION
E01	<ol style="list-style-type: none"> 1. The motor is not working. 2. The cable does not work inside the device. 3. The display has no corresponding signal to the engine. 	<p>First check the connections of the sensor cables and check the sensor cables.</p> <ol style="list-style-type: none"> 1. Connect the plug or replace the motor. 2. Replace the cable. 3. Replace the electronic meter.
E02	Heart rate display does not work.	<p>First check the heart rate in another mode. If there is no heart rate display in the other mode, replace the receiver or the heart rate sensor wire. Hold the heart rate sensor on the handlebar by hand within 3 seconds after the test is started.</p>

NOTE

1. *This meter must be equipped with a 9V / 1A power adapter. If the meter isn't right is displayed, unplug the power cord and plug it in again.*
2. *This meter must be equipped with a 9V / 1A power adapter. If the meter isn't right is displayed, unplug the power cord and plug it in again.*

CONSOLE



BUTTON	FUNCTION
RECOVERY	To testing the level of heartbeat recovery.
RESET	Delete settings except the user defined U1 ~ U4, WATT, PULSE.
UP/DOWN	Adjust the function value up or down.
START/STOP	Start the training or resume training in stop mode.
ENTER	To changeover display WATT or RPM display in the working status ; .To choose set items in the stop status needs to be set.
DISPLAY-ALT	Lets you to select and lock on to a particular function you want.

FUNCTIONS

BUTTON	FUNCTION
TIME	The total cycling time from the beginning to the end of the exercise is displayed.
SPEED	The speed is displayed during training when you start training.
DISTANCE	The distance of each workout is displayed when you start exercising.
CALORIES	The total calories from the beginning to the end of the exercise is displayed.
PULSE	Keep your hands on the sensor for 3 seconds to display your heart rate.
RPM	Revolutions per minute.
WATTS	Displays the wattage.
SCAN	Functions change automatically every 6 seconds.

UNIT

HEIGHT	WEIGHT	KPH	RPM	DIST	CAL	WATT	PULSE
CM	KG	KM / H	R / MIN	KM	KCAL	W	BPM

PROGRAM SETTINGS

PROGRAM	EXPLANATION
MANUAL MODE	Program 1: adjust resistance level manually.
PROGRAM MODE	Program 2 ~ 11: Automatic resistance adjustment with preset values.
BODY FAT	Program 12: Percentage of body fat, body mass index (BMI) and basal metabolism
WATT MODE	Program 13: The resistance adjusts to the speed while the set wattage remains the same.
H.R.C. MODE	Program 14 ~ 17: The heart rate value is based on the movement mode (65%, 75%, 85%). The resistance adjusts to the speed so that the set heart rate remains the same.
USER MODE	Program 18 ~ 21: The voltage can be adjusted in different resistance levels.
RECOVERY MODE	Heart rate recovery status.

PROGRAM EXPLANATION

MANUAL MODE (PROGRAM 1)

1. Press "START" key to starting motion, or press "ENTER" key into setting.
2. In setting status, press "ENTER" key to choose setting items with relevant flashing window for TIME, DISANCE, CALORIE, AGE.
3. Press "UP" or "DOWN" key to upward or downward a adjusted, and press "ENTER" key to next
4. Automatically exits the set status when all operations are complete, or press "START" key in the settings status to start directly.
5. It can be adjusted the resistance value level freely during the motion status, with "UP" or "DOWN" key;
6. If time, distance, calories, or any of these are setting The corresponding value will be inverted in motion status. When any of setting value count to 0, t he motion will be STOP and "DI DI" Voice Prompt.
7. Press "STOP " key to STOP the motion, in the motio.

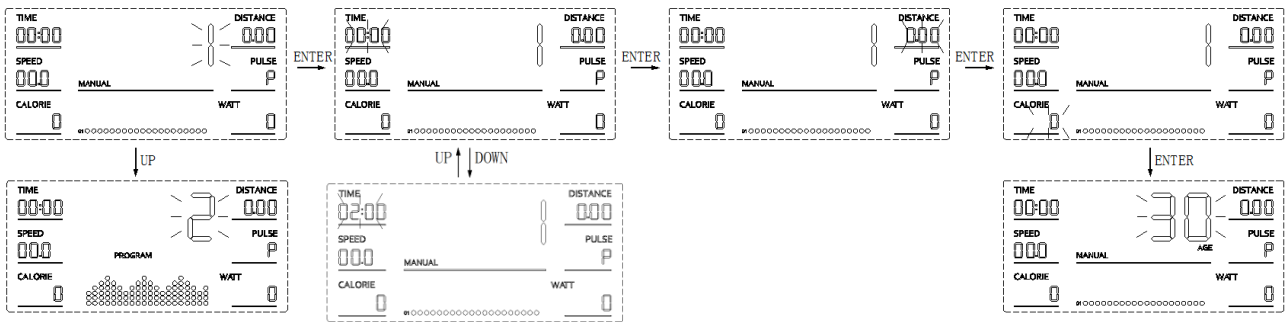

PROGRAM MODE (PROGRAM 2-11)

1. Press "UP" or "DOWN" key to select a particular function you want.
2. Press "START" key to starting motion, or press "ENTER" key into setting mode.
3. In setting status, press "ENTER" key to choose setting items with relevant flashing window for TIME, DISANCE, CALORIE, AGE.
4. Press "UP" or "DOWN" key to upward or downward a adjusted, and press "ENTER" key to next.
5. Automatic ally exits the set status when all operations are complete, or press "START" key in the settings status to start directly.
6. It can be adjusted the resistance value level automatic during the motion status with program, or press "UP" "DOWN" to manual adjustment.
7. If time, distance, calories, or any of these are setting The corresponding value will be inverted in motion status. When any of setting value count to 0, the motion will be STOP and "DI DI" VoicE Prompt.
8. Press "STOP " key to STOP the motion , in the motion status.

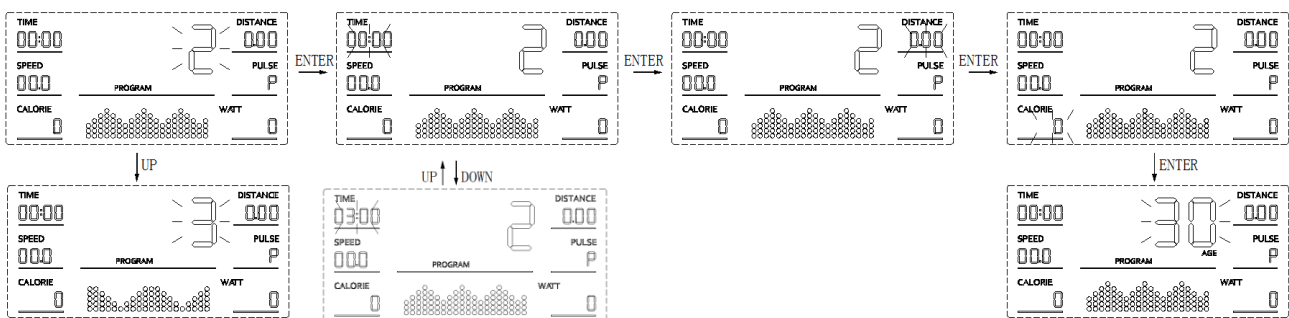

BODY FAT (PROGRAM 12)

1. Press "ENTER" key into setting mode;
2. In setting status, press "ENTER" key to choose setting items with relevant flashing window for GENDER - HIGHT - WEIGHT - AGE.
3. Press "UP" or "DOWN" key to upward or downward a adjusted, and press "ENTER" key to next item. Press "START" key to starting test and. Hold the pulse sensor. Then the display will show your body fat in 8 seconds later.

1. You should keep your body relaxed and your heart rate calm.

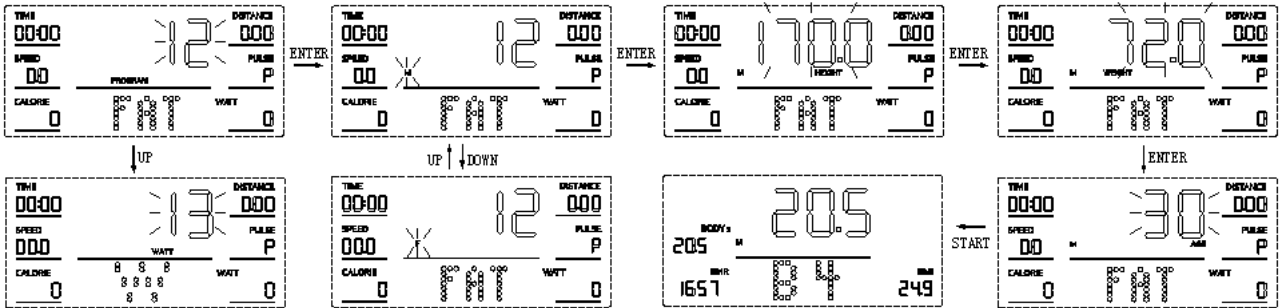

B.M.I. (BODY MASS INDEX)

GENDER / AGE	UNDER WEIGHT	HEALTHY	SLIGHTLY OVERWEIGHT	OVER WEIGHT	OBESE
MALE <30	< 14%	14% - 20%	20.1% - 25%	25.1% - 35%	> 35%
MALE >30	< 17%	17% - 23%	23.1% - 25%	28.1% - 38%	> 38%
FEMALE <30	< 17%	17% - 24%	24.1% - 30%	30.1% - 40%	> 40%
FEMALE >30	< 20%	20% - 27%	27.1% - 33%	33.1% - 43	> 43%

BODY FAT

GENDER	LOW	MEDIUM	SLIGHTLY HIGHT	HIGHT
MALE	< 13%	13% - 25.9%	26% - 30%	> 30%
FEMALE	< 17%	17% - 23%	23.1% - 25%	> 40%

B.M.R (BASAL METABOLIC RATE): The average number of calories burned per day for basic survival.

- Ref: 1300 ± 100 (22 - 40 years).

BODY TYPE

B1	B2	B3	B4	B5	B6	B7	B8	B9
Skinny	Obese	Slightly thin	Slim	Healthy	Slightly overweight	Overweight	Obese	Obesity

WATT MODE (PROGRAM 13)

1. Press "ENTER" key into setting mode.
2. In setting status, press "ENTER" key to choose setting items with relevant flashing window for TIME - DISTANCE - WATT.
3. Press "UP" or "DOWN" key to upward or downward a adjusted, and press "ENTER" key to next.
4. Press "START" key to starting.
5. It can be adjusted the resistance value level automatic during the motion status with WATT target value, or press "UP" "DOWN" to manual adjustment.
6. If time, distance, calories, or any of these are setting The corresponding value will be inverted in motion status. When any of setting value count to 0, the motion will be STOP and "DI DI" Voice Prompt.
7. Press "STOP" key to STOP the motion, in the motion

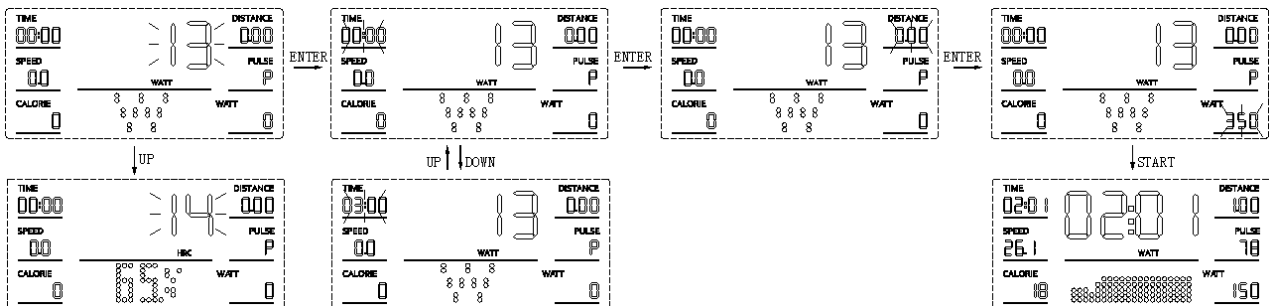

H.R.C MODE (PROGRAM 14-17)

1. Press "UP" or "DOWN" key to select a particular function you want.
2. Press "START" key to starting motion, or press "ENTER" key into setting mode.
3. In setting status, press "ENTER" key to choose setting items with relevant flashing window for TIME - DISTANCE - CALORIE - AGE (only PROGRAM14 16). T.H.R (only PROGRAM17).
4. Press "UP" or "DOWN" key to upward or downward a adjusted, and press "ENTER" key to next.
5. Press "START" key to starting.
6. It can be adjusted the resistance value level automatic during the motion status with T.H.R target value, or press "UP" "DOWN" to manual adjustment.
7. If time, distance, calories, or any of these are setting. The corresponding value will be inverted in motion status. When any of setting value count to 0, the motion will be STOP and "DI DI" Voice Prompt.

1. Press "START/STOP" key to STOP the motion , in the motion status;" key to STOP the motion, in the motion status.

NOTE: You must be hold the pulse sensor in during exercise.

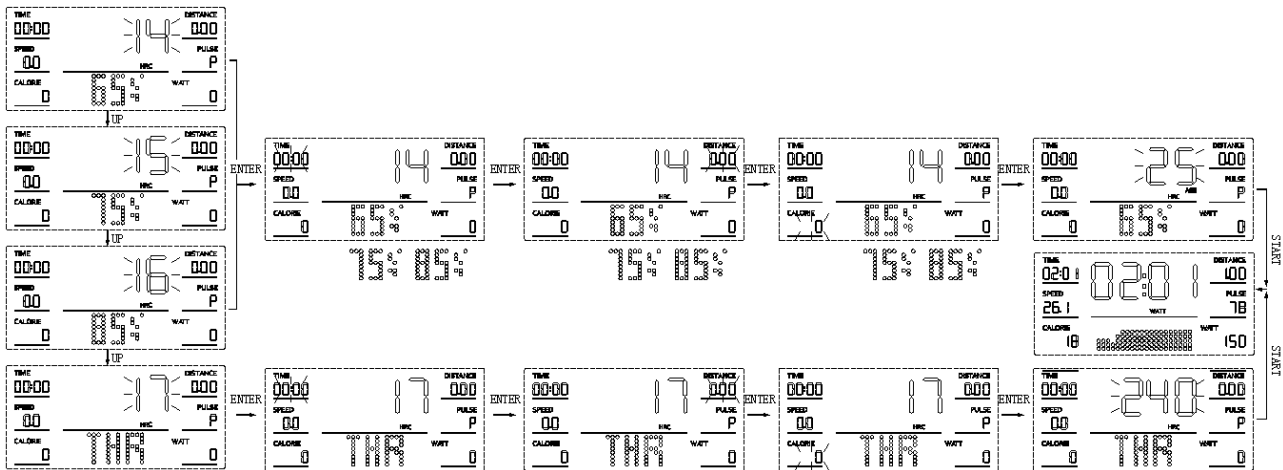

USER MODE (PROGRAM 18-21)

1. Press "UP" or "DOWN" key to select a particular function you want.
2. Press "START" key to starting motion, or press "ENTER" key into setting.
3. In setting status, press "ENTER" key to choose setting items with relevant flashing window for TIME - DISTANCE - CALORIE - AGE - Resistance Value.
4. Press "UP" or "DOWN" key to upward or downward a adjusted, and press "ENTER" key to next.
5. Press "START" key to starting.
6. It can be adjusted the resistance value level autom atic during the motion status, or press "UP""DOWN" to manual adjustment.
7. If time, distance, calories, or any of these are setting. The corresponding value will be inverted in motion status. When any of setting value count to 0, the motion will be STOP and "DI Voice Prompt.
8. Press "STOP " key to STOP the motion, in the motion.

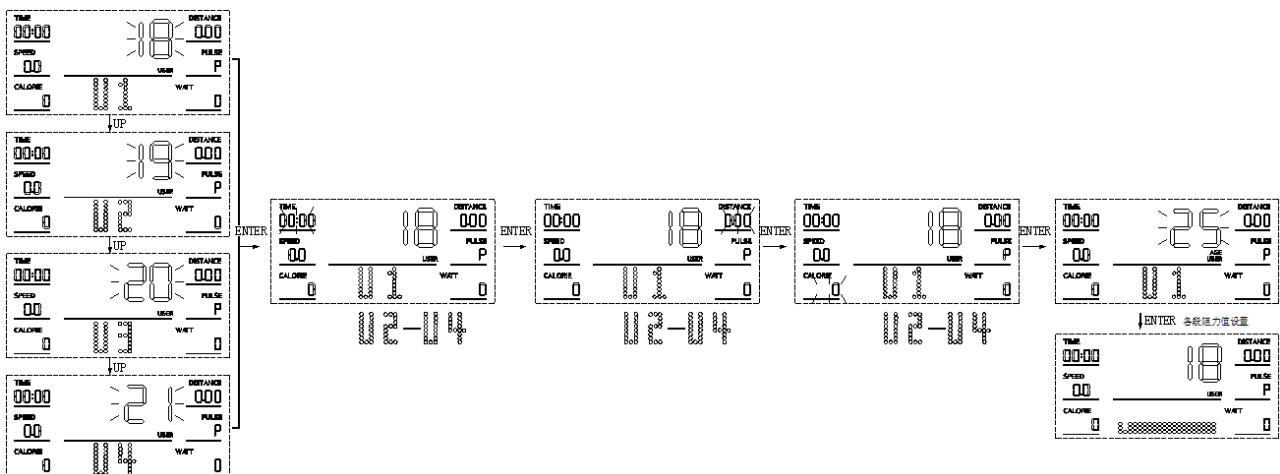

RECOVERY MODE

In exercising status, first test your pulse as above mentioned. Then press “RECOVERY” key to enter pulse recovery function. The display will show 1 minute count down as well as your pulse rate. Hold on the pulse sensor until it counts down to zero. Then, it will pop up your pulse recovery level from F1 to F6, that is, from the fastest recovery to slowest. The fastest recovery F1 show the best.

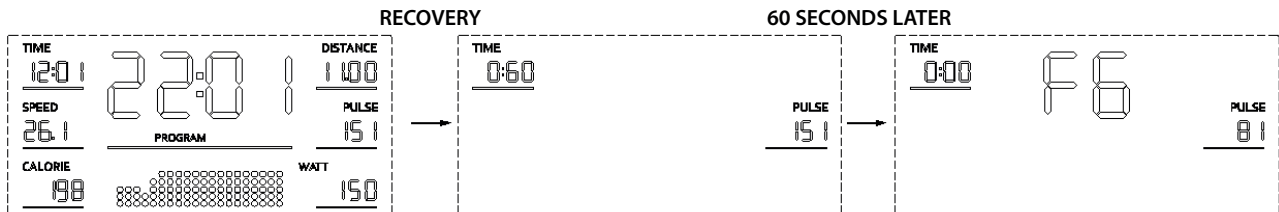

INSTRUCTION

1. QR code scanner app is required to scan the QR code with an Android or IOS phone or tablet. This app can be downloaded in the App Store or Google Play Store.
2. Scan one of the QR codes below to go directly to the place in the App Store or Google Play Store where the app is located and can be downloaded.
3. Scan the QR code on the right to go to the user manual of the app. The manual describes step by step how the app should be connected to the device, how the app works and what the options are.

FITSHOW

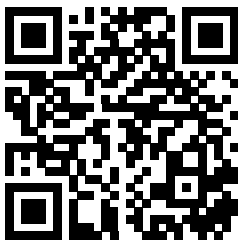

APP STORE
FITSHOW



GOOGLE PLAY
FITSHOW

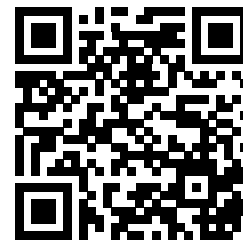

USER MANUAL
FITSHOW

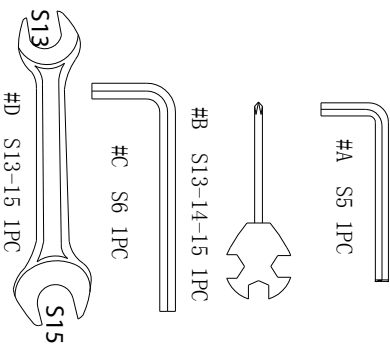
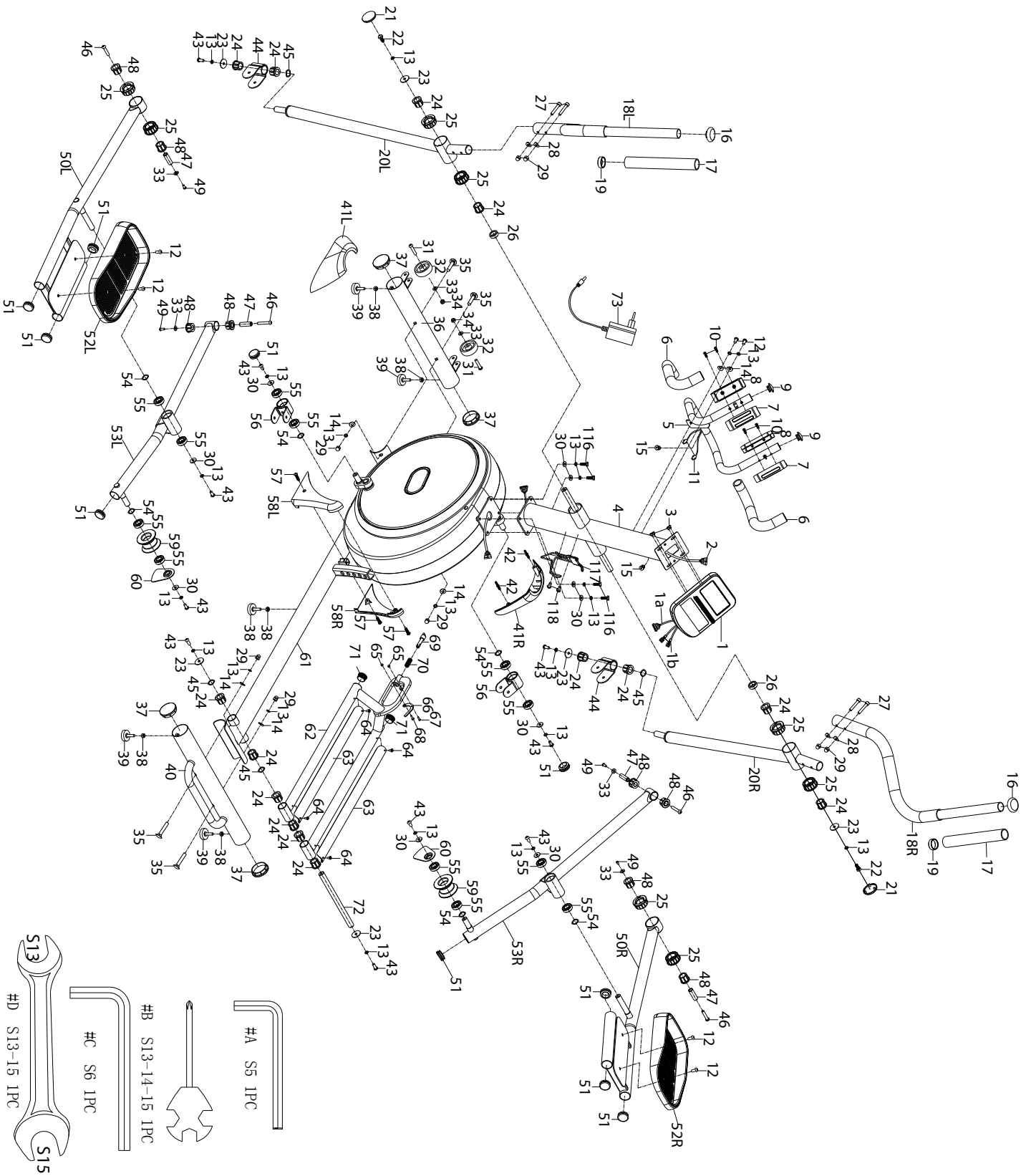

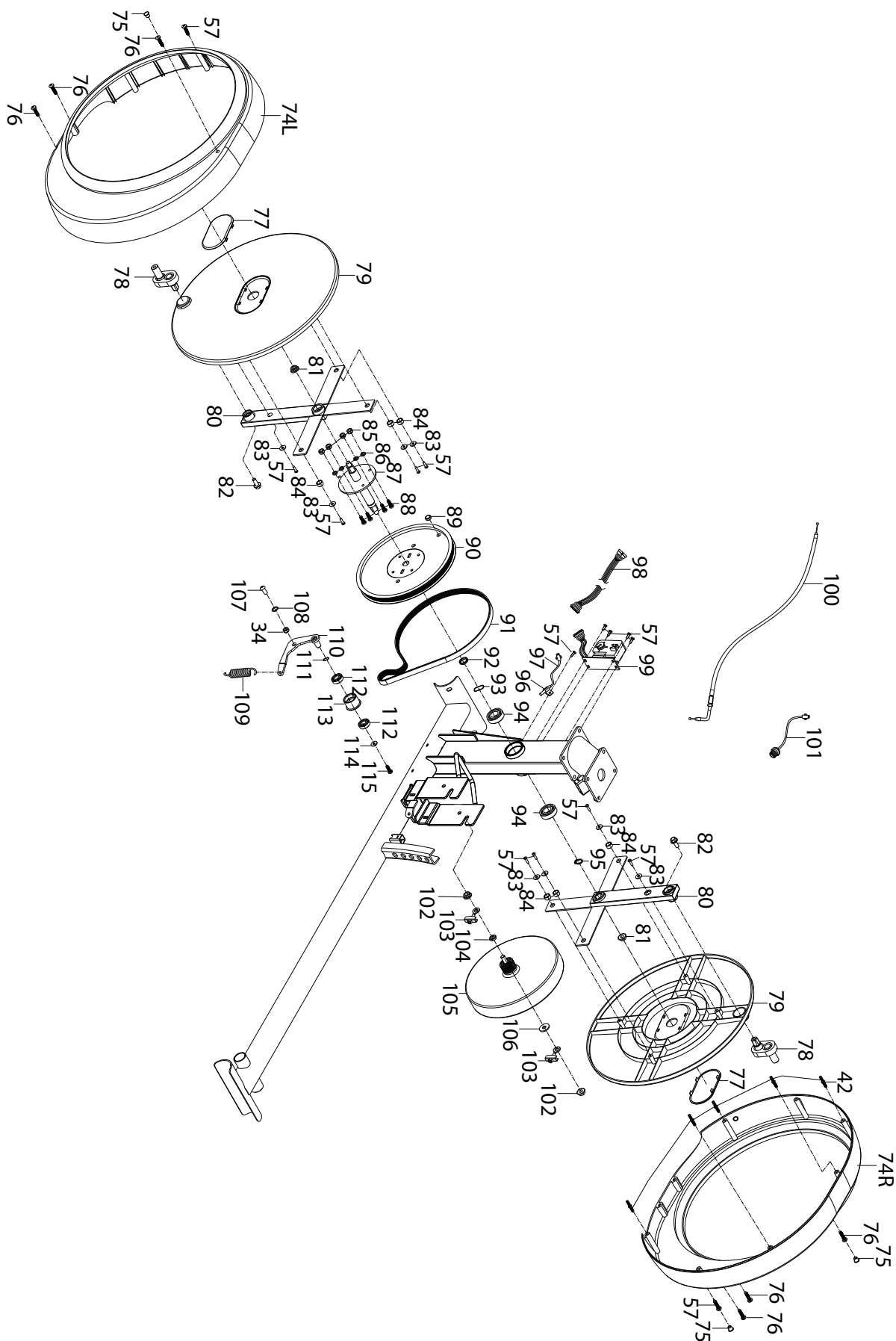

#	DESCRIPTION	QTY	#	DESCRIPTION	QTY
1	Display	1	31	Inner hex pan head M8*42*15*S5	2
2	Extension wire 1	1	32	Transportation wheelφ62*25.5*φ8.5	2
3	Cross pan head screw M5*10	4	33	Washer d8*Φ16*1.5	6
4	handlebar post	1	34	Nylon nut M8*H7.5*S13	3
5	Middle handlebar	1	35	Square neck bolt M8*73*20*H5	4
6	Handlebar foam Φ23*3*350	2	36	Front stabilizer	1
7	Top handle pulse	2	37	End cap Φ60.5*17	4
8	Bottom handle pulse	2	38	Hexagonal nut M8	5
9	End cap	2	39	Rubber foot pad φ52*18*M8*25	5
10	Cross pan head screw ST3*25	4	40	Rear stabilizer	1
11	Handle pulse wire	2	41L/R	Handlebar post cover	2
12	Inner hex pan head bolt M8*20*S5	6	42	Connection bar	7
13	Spring washer d8	22	43	Inner hex pan bolt M8*16*S5*φ13	10
14	Curve washer d8*Φ20*2*R30	6	44	Reciprocating joint	2
15	Wire holder Φ12	2	45	Corrugated washer d19*Φ25*0.3	4
16	End cap Φ32	2	46	Inner hex bolt M8*50*M6*15*S5	4
17	Handlebar foam Φ30*3*270	2	47	Spacer Φ14*Φ8.2*45.2	4
18L/R	Left/right handlebar	2	48	Shaft sleeve Φ32*3.3*Φ28*16*Φ14	8
19	Aluminum ring Φ37.5*φ32.5*12	2	49	Inner hex pan head bolt M6*15*S5	4
20L/R	Reciprocating bar	2	50L/R	Left and right pedal support tube	2
21	End cap Φ50*5	2	51	End cap φ38*17	10
22	Hexagonal bolt M8*16*S14	2	52L/R	Pedal 380*185*49	2
23	Washer d8*Φ32*2	6	53L/R	Left and right linkage	2
24	Shaft sleeve 4	14	54	Corrugated washer d17*Φ22*0.3	6
25	Shaft sleeve Φ50*Φ28*20	8	55	Bearing 6003	12
26	Rubber spacer Φ30*Φ20*10	2	56	Linkage joint	2
27	Hex cylinder bolt M8*45*S6*φ12	4	57	Cross pan head self-drilling screw	18
28	Curve washer d8*Φ20*2*R19	4	58L/R	Slope cover	2
29	Cap nut M8*H16*S13	8	59	Wheel Φ70*45	2
30	Washer d8*Φ20*2	10	60	Loose proofed board	2

#	DESCRIPTION	QTY
61	Mainframe	1
62	Guide rail	1
63	Aluminum guide rail	2
64	Cross pan head screw M5*10*φ8	4
65	Cap nut M4*H7*S7	2
66	Incline adjustment handle	1
67	Cross pan head screw M4*12*φ8	1
68	Cross pan head screw M4*16*φ8	1
69	Spring washer φ15*64	1
70	Spring φ1.5*φ14.5*50*N12	1
71	End cap φ32*17	2
72	Shaft	1
73	Adaptor	1
74L/R	Chain cover	2
75	End cap for hole	3
76	Cross pan head self-drilling screw	6
77	Cap for holes	2
78	Small crank	2
79	Round Plate	2
80	Crank	2
81	Flange nut M10*1.25*H7.5*S14	2
82	Flange nut M8*20	2
83	Washer d6*φ16*1.5	8
84	Spacer φ15*φ12*8	6
85	Nylon nut M6*H6*S10	4
86	Spring washer d6	4
87	Middle shaft	1
88	Hexagonal bolt M6*16*S10	4
89	Plastic dipping round magnet	1
90	Belt wheelφ260	1
91	Belt	1

#	DESCRIPTION	QTY
92	Spacer Φ25*Φ20.2*4	1
93	Corrugated washer d20	1
94	Bearing 6004	2
95	Circlip for shaft d20	1
96	sensor seat	1
97	Sensor	1
98	Extension wire 2	1
99	Motor	1
100	Resistance wire	1
101	Power cable	1
102	Flange nut M10*1*H8*S15	2
103	Chain adjustment bolt	2
104	Hexagonal thin nut M10*1*H5*S17	1
105	Flywheel	1
106	Washer d10*Φ20*2	1
107	Flat shoulder head bolt	1
108	Washer d12*φ17*0.5	1
109	Spring Φ3.2*Φ20.2*60	1
110	Inertial wheel frame	1
111	Corrugated washer d12	1
112	Bearing 6001	2
113	Free wheel	1
114	Washer d6*Φ16	1
115	Hexagonal boltM6*12*S10	1
116	Hexagonal bolt M18*20*S13	4
117	Bottle holder	1
118	Cross pan head screw M5*10*φ10	2
A	Hex wrench S5	1
B	Cross Solid wrench S13-14-15	1
C	Hex wrench S6	1

A successful exercise program consists of a warm-up, aerobic exercise, and a cool-down. Do the entire program at least two and preferably three times a week, resting for a day between workouts. After several months, you can increase your workouts to four or five times per week.

WARMING UP

The purpose of warming up is to prepare your body for exercise and to minimize injuries. Warm up for two to five minutes before strength-training or aerobic exercising. Perform activities that raise your heart rate and warm the working muscles. Activities may include brisk walking, jogging, jumping jacks, jump rope, and running in place.

STRETCHEN

Stretching while your muscles are warm after a proper warm-up and again after your strength or aerobic training session is very important. Muscles stretch more easily at these times because of their elevated temperature, which greatly reduces the risk of injury. Stretches should be held for 15 to 30 seconds.

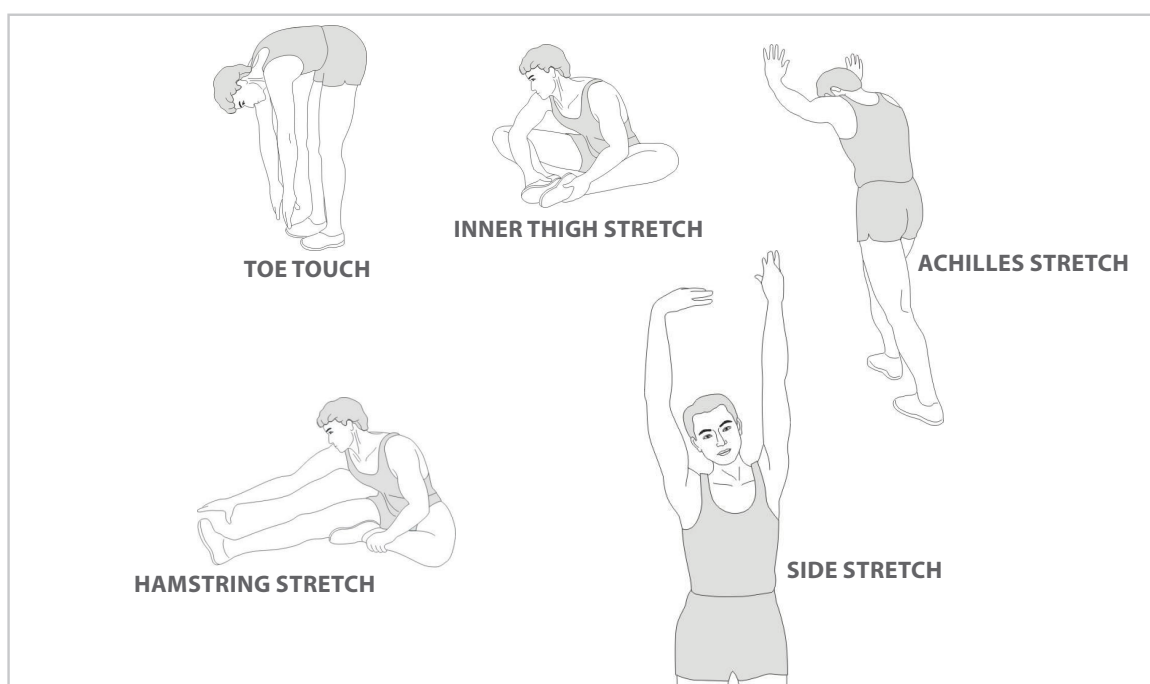

COOLING DOWN

The purpose of cooling down is to return the body to its normal or near normal, resting state at the end of each exercise session. A proper cool-down slowly lowers your heart rate and allows blood to return to the heart.

virtu profit

For questions or missing parts please contact your dealer.